

1310TX DFB 1550RX PD BOSA 2GHz CATV Transmission

OSMTRPD32xxx510MxxxxG

Features:

- ◆ Coaxial Package
- ◆ InGaAsP/InP MQW-DFB Laser Diode
- ◆ Low threshold, high slope efficiency and high output power
- ◆ Data Rate up to 2.5G
- ◆ Single-mode fiber pigtailed with SC FC ST or LC connector
- ◆ High channel isolation
- ◆ Low return loss
- ◆ Optional with Isolator
- ◆ Operating Case Temperature: -20°C to +85°C
- ◆ RoHS Compliant Products Available



Applications:

- ◆ Long distance digital transmission system
- ◆ Cable television system
- ◆ WDM systems

Absolute Maximum Ratings: ^{*Note1}

Parameter	Symbol	Ratings	Unit
Storage Temperature	Tstg	-40~+85	°C
Operating Case Temperature	Top	-20~+85	°C
Reverse Voltage (Monitor PD)	V _{RD}	20	V
Photodiode Forward Current (Monitor PD)	I _{FD}	2	mA
Lead Soldering (Temperature)/(Time)	---	260/10	°C/Sec
Reverse Voltage (Analog PD)	V _{rpd}	30	V
Forward Current (Analog PD)	I _{fpd}	10	mA

*Note1: Exceeding any one of these values may destroy the device immediately.

Electrical and Optical Characteristics – Transmitter:

($I_f = I_{th} + 20\text{mA}$, $P_f = 1\text{mW}$, SMF (9.5/125 μm), $T_c = +25 \pm 2^\circ\text{C}$, unless otherwise noted.)

Parameter	Symbol	Condition	Min.	Typ.	Max.	Unit
Threshold Current	I_{th}	at $T_c = 25 \pm 3^\circ\text{C}$	---	10	15	mA
Output Power (After coupled)	P_f	CW, $I_{op} = I_{th} + 20\text{mA}$	1.0	---	2.99	mW
Slope Efficiency	S_e	CW, Average	0.05	---	0.15	mW/mA
Operating Voltage	V_{op}	CW, $I_{op} = I_{th} + 20\text{mA}$	---	1.1	1.6	V
Peak Wavelength	λ_c	CW, $I_{op} = I_{th} + 20\text{mA}$, $T_c = -20 \sim 85^\circ\text{C}$	1290	1310	1330	nm
Side Mode Suppression Ratio	SMSR	CW, $I_{op} = I_{th} + 20\text{mA}$, $T_c = -20 \sim 85^\circ\text{C}$	35	40	---	dB
Monitor Current	I_{mon}	CW, $I_{op} = I_{th} + 20\text{mA}$	0.1	---	1.0	mA
Monitor Dark Current	I_d	$V_{RD} = 5\text{V}$	---	---	0.1	μA
Relative intensity Noise	---	---	---	---	-145	dB/Hz
Optical Isolation	I_{so}	---	30	---	---	dB
Tracking Error	TE	APC, $-20^\circ\text{C} \sim +85^\circ\text{C}$	-1.5	---	1.5	dB
Rise/Fall Time	T_r/T_f	$I_b = I_{th}$, 20~80%	---	0.1	0.15	ns

Electrical / Optical Specifications – Receiver:

Parameter	Symbol	Test Condition	Min.	Typ.	Max.	Unit
Operating Wavelength ^{*Note2}	λ	---	1500	1550	1600	nm
Active Area	Φ	---	---	75	---	μm
-3dBm Bandwidth	BW	$V_R = 5\text{V}$	2	---	---	GHz
Dark Current	I_d	$V_R = 5\text{V}$	---	---	1.0	nA
Responsivity	R	$\lambda = 1550\text{nm}$	---	0.80	---	A/W

*Note2: Receiver Operating Wavelength can be customized.

Pin Assignment: ^{*Note3}

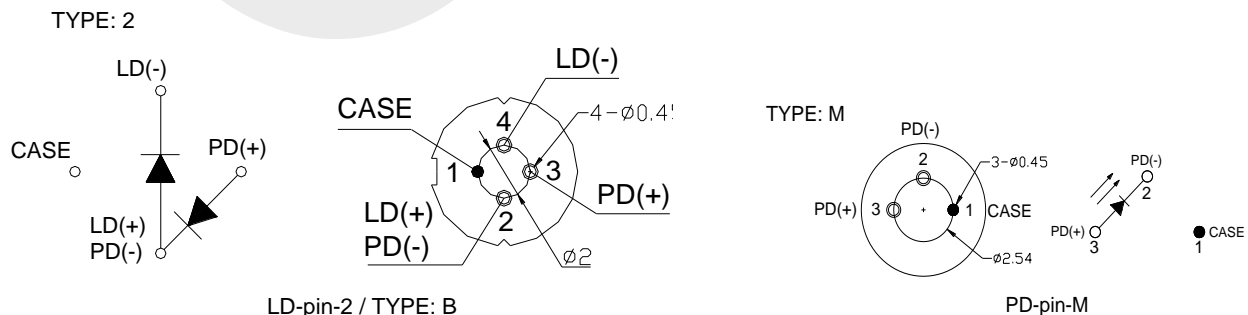

*Note3: Pin assignment can be customized.

Package Dimension: *Note4

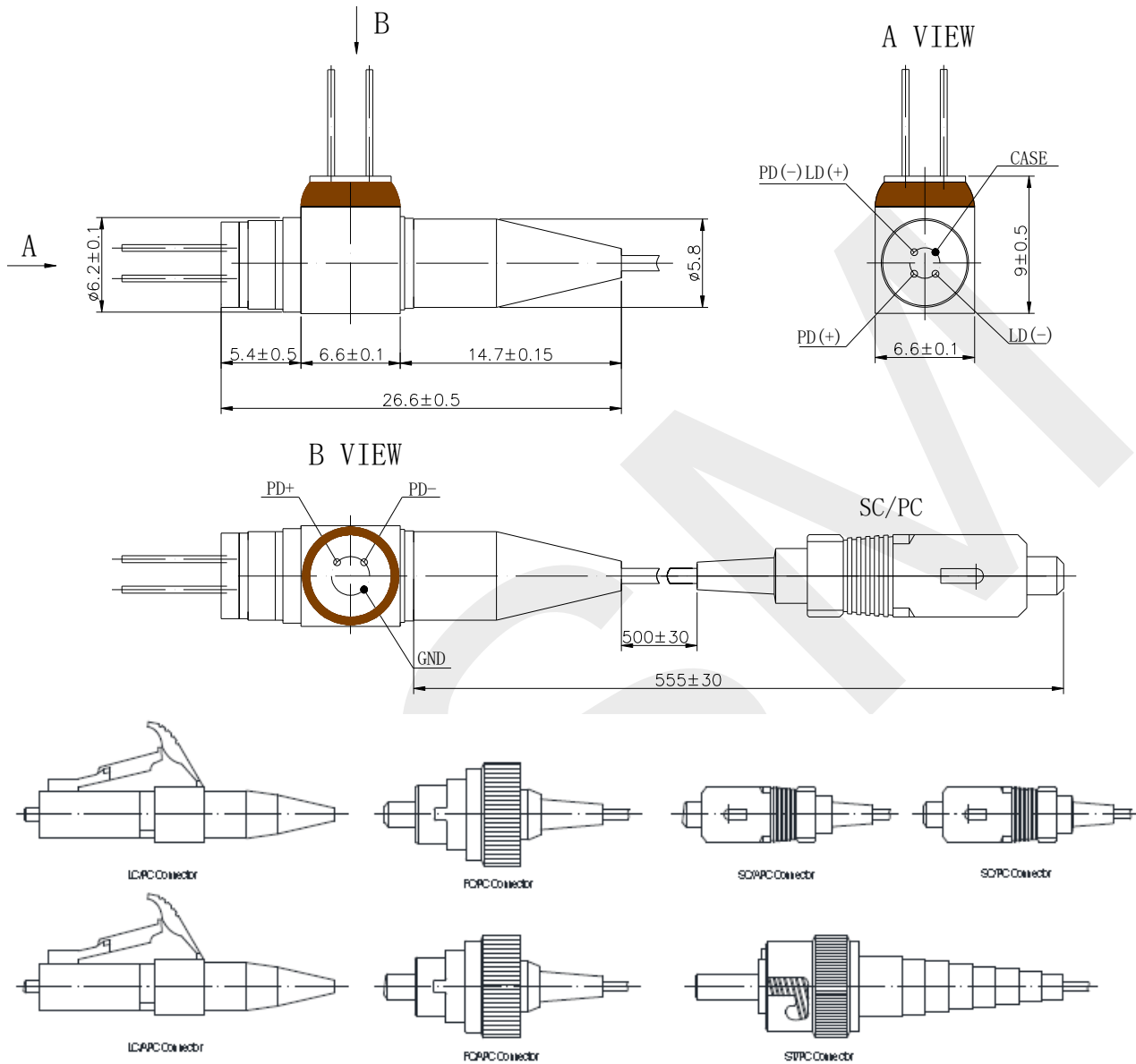

*Note4: PIN direction and laser mark can be customized

TX Pin Order Code: *Note5、6、7

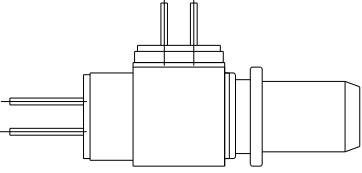
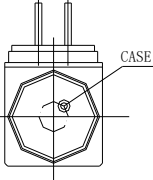
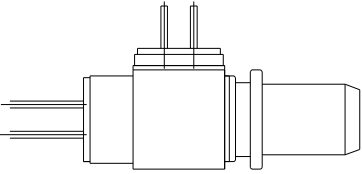
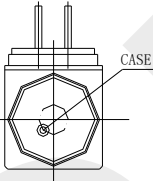
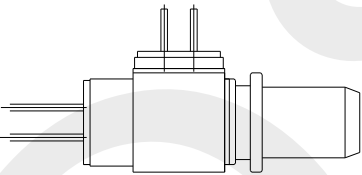
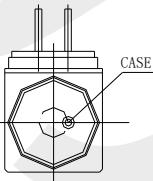
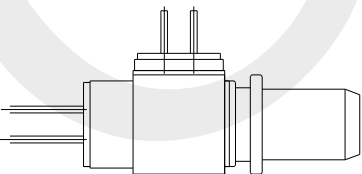
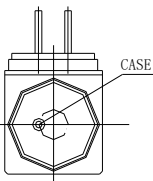
Launch			
			
Case direction	A Type	Case direction	B Type
			
Case direction	C Type	Case direction	D Type
			
Case direction	E Type	Case direction	F Type
			
Case direction	G Type	Case direction	H Type

Note5、 This picture is for pluggable, pigtail BIDI chip PIN package direction's reference.

Note6、 This picture is suitable for RX Pin direction comparison .

Note7、 The package direction is described as "x-x" For example "A-B", "A" is TX chip Pin direction, "B" is RX chip Pin direction.

RX Pin Order Code:

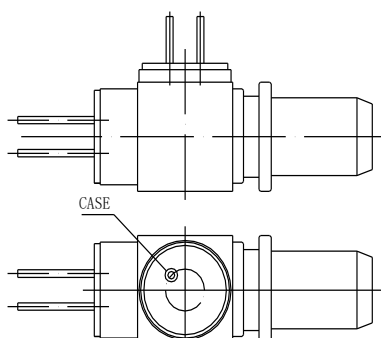
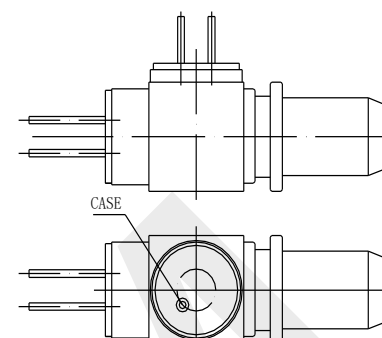
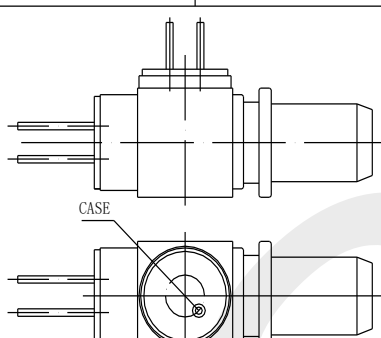
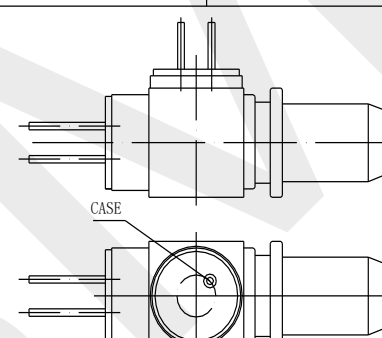
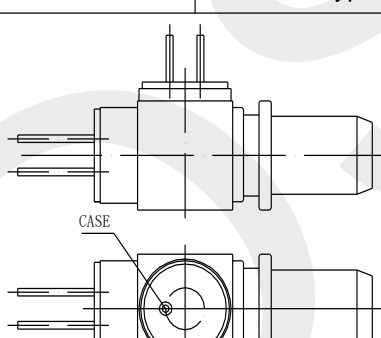
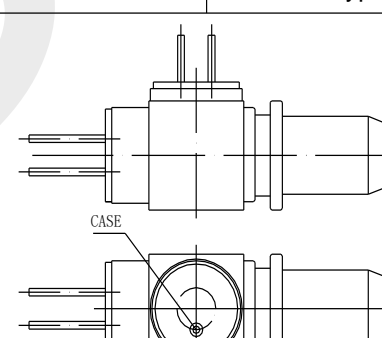
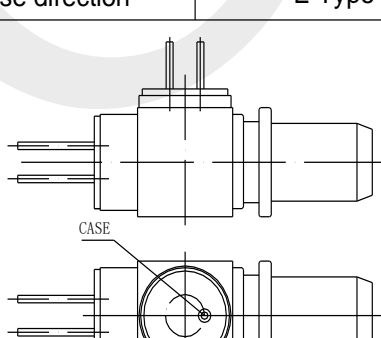
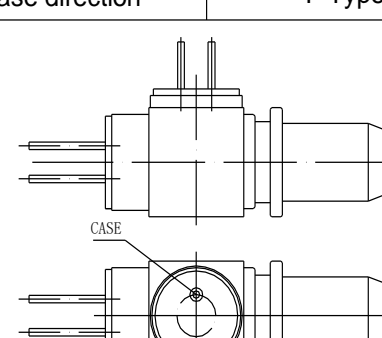
Receive			
			
Case direction	A Type	Case direction	B Type
			
Case direction	C Type	Case direction	D Type
			
Case direction	E Type	Case direction	F Type
			
Case direction	G Type	Case direction	H Type

Nomenclature:

OSMBIDI-□ □ □ □ □ □ □ □ □ □ □ □ □
 A B C D E F G H I J K L M

Code	Parameter	Detailed Description							
A	Laser Type	D=DFB LD							
B	Launch Wavelength	3=1310nm							
C	Launch Data Rate	1=1.25G				2=2.5G			
D	Output Power	10=1~1.99mW				20=2.0~2.99mW			
E	Receiver Wavelength	5=1550nm							
F	Active Diameter	1=75um							
G	Bandwidth	0≤2GHz		1≤2.5GHz			2≤3.2GHz		
H	Connector	F=FC/PC		S= SC/PC		T=ST/PC		L=LC/PC	
		SA= SC/APC		FA=FC/APC		LA=LC/APC		BLANK =None	
I	TX Pin Package Direction	A	B	C	D	E	F	G	H
J	RX Pin Package Direction	A	B	C	D	E	F	G	H
K	RX TO Insulated With Shell	Blank= Insulation				N=NO Insulation			
L	Isolator	Blank=None				G=with I			
M	Fiber Length	Blank=50cm		035=35cm		100=100cm		XXX=Custom	

Precaution:

- (1) The modules should be handled in the same manner as ordinary semiconductor devices to prevent the electro-static damages. For safe keeping and carrying, the modules should be packaged with ESD proof material. To assemble the modules on PCB, the workbench, the soldering iron and the human body should be grounded.
- (2) Please pay special attention to the atmosphere condition because the dew on the module may cause some electrical damages.
- (3) Under such a strong vibration environment as in automobile, the performance and reliability are not guaranteed.

Notice:

OSM reserves the right to make changes or discontinue any product or service identified in this publication, without notice, in order to improve design and/or performance. Applications that are described herein for any of the products are for illustrative purposes only. OSM makes no representation or warranty that such applications will be suitable for the specified use without further testing or modification.